



TO INFORM YOU

PRODUCT SUPPORT BULLETIN # 357

TO: AUTHORIZED *Portable Electric Tool* SERVICE STATIONS
factory SERVICE CENTERS
SALES COMPANIES

DATE: MARCH, 2001

FROM: Corbert A. Garb - National Service Manager

TOOL(S) \ PRODUCT(S) AFFECTED

1610-1, 1630-1 1/2" Compact Hole-Shooter Drill, 1670-1, 1675-1 1/2" Hole-Hawg® Drill

SUBJECT: - PRODUCT SAFETY RECALL -

For operator safety and to comply with requirements of the U.S. Consumer Products Safety Commission [CPSC] the Management of Milwaukee Electric Tool Corporation wants you to be aware of a defect existing in some **1610-1, 1630-1 1/2" Compact Hole-Shooter Drills** and **1670-1, 1675-1 1/2" Hole-Hawg® Drills**.

1610-1, 1630-1 1/2" Compact Hole-Shooter Drill and **1670-1, 1675-1 1/2" Hole-Hawg® Drill**, within the serial number ranges shown below and sold between May 30, 2000 and February 27, 2001 are affected. Please see enclosed – **SAFETY RECALL** – poster.

Nameplate Catalog Number

Serial Number Range

1610-1	700B400200013 thru 700B400480097
1630-1	718B400230057 thru 718B400480118
1670-1	472B400200061 thru 472B400440188
1675-1	413B400190567 thru 413B400522000

For operator safety a **1610-1, 1630-1 1/2" Compact Hole-Shooter Drills** and **1670-1, 1675-1 1/2" Hole-Hawg® Drill** listed above, received for repair, **must be inspected** for the presence of a **23-66-1020 Switch** with a date code within 0021 through 0044 [21st thru 44th week of 2000]. If the unit contains a recalled 23-66-1020 Switch please complete an Individual Tool Warranty Report form covering the no-charge replacement of the switch, highlighting in yellow the Catalog & Serial number of the Drill. Please enclose the replaced defective 'recalled' switch with the copy of the Individual Tool Warranty Claim form when submitting for payment. No credit will be issued for a warranty claim that does not have a switch returned with it. Please see To Inform You/ Product Support Bulletin #358.

PLEASE POST THE ENCLOSED – SAFETY RECALL – POSTER FOR ALL CUSTOMERS TO READ.

Stamp or etch an **'X'** next to the ending digit of the serial number on the tool's nameplate after the replacement of a recalled 23-66-1020 Switch.

The **'X'** will show that the drill has been repaired.



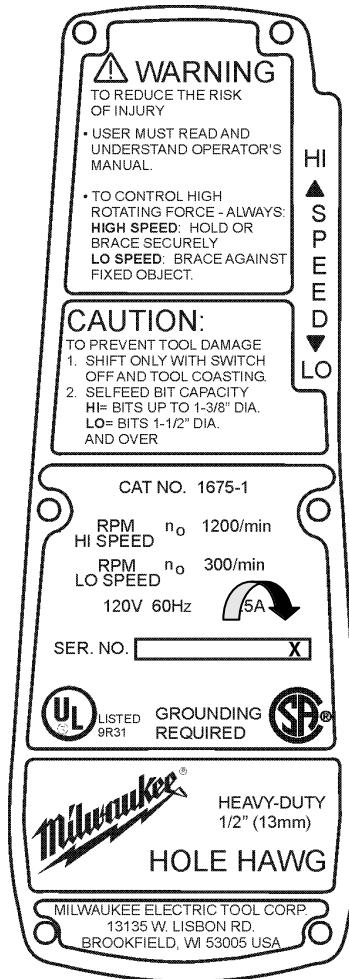

1610-1, 1630-1 1/2" Compact Hole-Shooter Drills and 1670-1, 1675-1 1/2" Hole-Hawg® Drills being re-worked at the plant of manufacture will also carry an 'X' stamped into the tool's nameplate, showing that the drill has been repaired.

← Stamp or etch an 'X' next to the ending digit of the serial number

The 'X' is used to assure a customer that the drill in question has been **inspected** for the presence of a **23-66-1020** Switch and that the defective switch has already been **replaced**. Also, it will eliminate the need to re-inspect Compact and Hole-Hawg® Drills received for repair for the presence of a recalled 23-66-1020 Switch.

SAFETY RECALL

MILWAUKEE ELECTRIC TOOL CORPORATION IN COOPERATION WITH THE U.S. CONSUMER PRODUCT SAFETY COMMISSION (CPSC), ANNOUNCES A RECALL OF CERTAIN 1/2" MILWAUKEE ELECTRIC DRILLS. THESE DRILLS MAY CONTAIN A SWITCH THAT STICKS IN THE "ON" POSITION WHICH COULD RESULT IN OPERATOR INJURY. THERE HAS BEEN ONE REPORT OF A CONSUMER SUSTAINING A MINOR HAND INJURY.

DRILLS THAT MAY BE INCLUDED IN THIS RECALL HAVE CATALOG NUMBERS 1610-1, 1630-1, 1670-1, 1675-1, 1675-6 OR 1676-6 ON THE DRILL'S NAMEPLATE.

CAT. NO. 1610-1
SERIAL NUMBER
700B400200013
THRU
700B400480097

CAT. NO. 1630-1
SERIAL NUMBER
718B400230057
THRU
718B400480118



CAT. NO. 1670-1
SERIAL NUMBER
472B400200061
THRU
472B400440188

CAT. NO. 1675-1
(ALSO SOLD AS 1675-6 & 1676-6)
SERIAL NUMBER
413B400190567
THRU
413B400522000

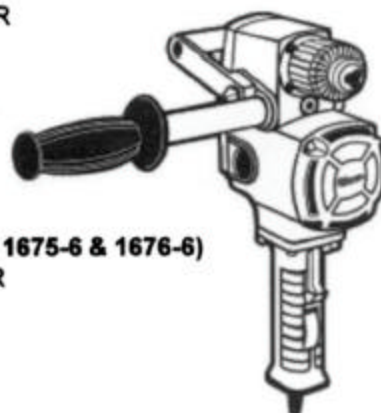

IF THE NAMEPLATE HAS AN "X" STAMPED OR ETCHED ON IT NEXT TO THE SERIAL NUMBER, THE TOOL HAS BEEN REPAIRED.

IF YOU HAVE ONE OF THESE DRILLS, STOP USING IT IMMEDIATELY AND RETURN THE DRILL TO THE NEAREST MILWAUKEE FACTORY SERVICE CENTER OR MILWAUKEE AUTHORIZED POWER TOOL SERVICE STATION FOR REPAIR AT NO CHARGE. FOR ASSISTANCE IN LOCATING YOUR NEAREST FACILITY CALL MILWAUKEE TOLL FREE AT:

1-866-473-2288

8:00AM AND 4:30PM CENTRAL TIME
MONDAY THROUGH FRIDAY

YOU CAN ALSO LOCATE A SERVICE FACILITY ONLINE AT www.mil-electric-tool.com. OTHER QUESTIONS SHOULD BE DIRECTED TO THE MILWAUKEE PRODUCT SERVICE STAFF AT 1-800-274-9804 BETWEEN 8:00AM AND 4:30PM CENTRAL TIME.

IF IT IS NECESSARY TO SHIP YOUR DRILL, WE RECOMMEND THAT RETURNS BE MADE VIA UNTIED PARCEL SERVICE (UPS). MILWAUKEE WILL REIMBURSE TOOL OWNERS FOR THIS EXPENSE. PLEASE NO UPS/C.O.D. RETURNS FOR SHIPPING CHARGES.



MILWAUKEE ELECTRIC TOOL CORPORATION
13135 WEST LISBON ROAD • BROOKFIELD, WISCONSIN 53005
1-800-274-9804
www.mil-electric-tool.com

POST UNTIL JULY 31, 2001